



SAP/SAPT 012-130 DIN is a series of light weight casing piston pumps with a fixed displacement for demanding mobile hydraulics.

SAP 012-108 DIN covers the displacement range 0.77-7.93 cu in/rev. at a maximum pressure of 5800 psi. It is a modern, compact pump which meets the market's high demands on flow performance, pressure, efficiency and small installation dimensions. The pump is either mounted directly on the power take-off or on a frame bracket via an intermediate shaft.

SAPT 090, 130 is an addition to the SAP series that supports larger flows and pressure up to 4350 psi. Ideal for applications that require both a high flow and a high working pressure.

Other advantages:

- Light weight metal casing design
- Smooth operation over the entire speed range
- Long life due to high demands on materials
- Corrosion free light metal-housing
- Less heat generation due to better ability to dissipate heat through housing

Versions, main data

Example

SA	P	-	084	L	-	N	-	DL4	-	L35	-	S0	S	-	0	00
Line	1		2	3		4		5		6		7	8		9	10

Line	
SA	Sunfab Aluminium

1. Type	
P	Pump
PT*	Tipper pump

*Only available in 090 and 130

2. Displacement	
012	017 025 034 040 047 056 064 084 090* 108 130*

*Only available as SAPT

3. Direction of rotation	
R	Right
L	Left

4. Shaft seal	
N	Nitrile
V*	HNBR

*Can withstand higher temperature, e.g. on engine PTO. Not available for 012-034.

5. Mounting flange	
DL4	DIN 4-h (ISO 7653D)

6. Shaft	
L35	DIN 5462 / ISO 14
H35*	DIN 5462 / ISO 14 Ø 8.15

*Not available on SAPT 090.

7. Connection cover	
S0	40° Sunfab standard

8. Connections	
S	Sunfab standard

9. Additional	
0	-

10. Accessories	
00	No accessories available

SAP/SAPT 012-108 DIN		012	017	025	034	040	047	056	064	084	090*	108	130*
rpm													
	500	1.7	2.2	3.4	4.5	5.4	6.2	7.5	8.4	11.0	11.9	14.3	17.2
	1000	3.3	4.5	6.7	9.0	10.9	12.4	15.0	16.8	22.1	23.8	28.5	34.3
	1500	5.0	6.7	10.1	13.6	16.3	18.7	22.5	25.2	33.1	35.7	42.8	51.5
Displacement													
cu in/rev													
		0.77	1.04	1.55	2.09	2.51	2.87	3.46	3.88	5.10	5.49	6.59	7.93
Max pump speed													
continuous rpm													
		2300	2300	2300	2300	1900	1900	1900	1900	1600	1500	1600	1500
intermittent													
		3000	3000	3000	3000	2500	2500	2500	2500	2100	2000	2100	2000
Max working pressure													
psi													
		5800	5800	5800	5800	5800	5800	5800	5800	5800	4350	5800	4350
Weight													
lb													
		15.2	15.2	15.7	15.7	21.6	21.6	21.6	21.6	30.6	21.6	30.6	30.6
Tare-weight torque (M)													
lb-ft													
		4.9	4.9	5.2	5.2	8.5	8.5	8.5	8.5	13.6	8.5	13.6	13.6
Direction of rotation													
Left (L) or Right (R)													

*SAPT

Dimensions SAP 012-034 DIN

Millimeter (inch)

DL4 ISO 7653-D

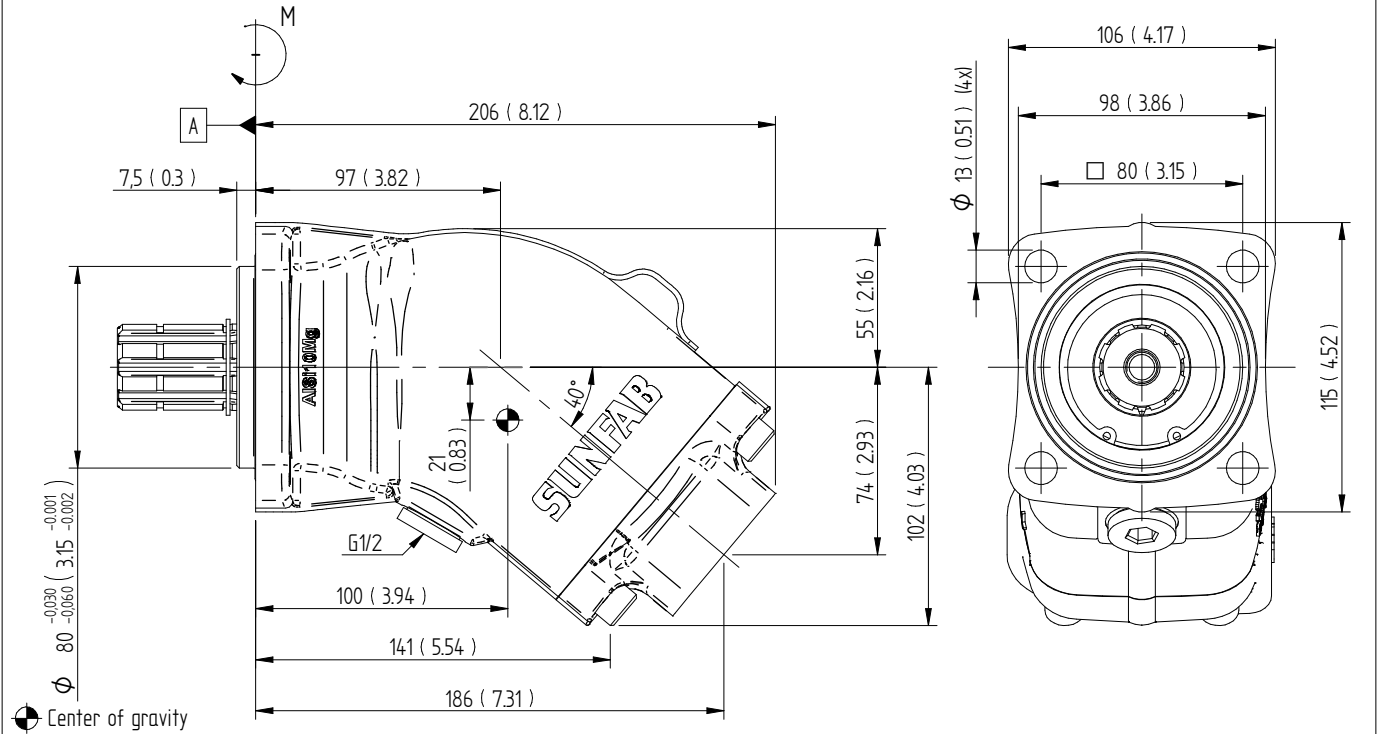

L35 DIN 5462 / ISO 14

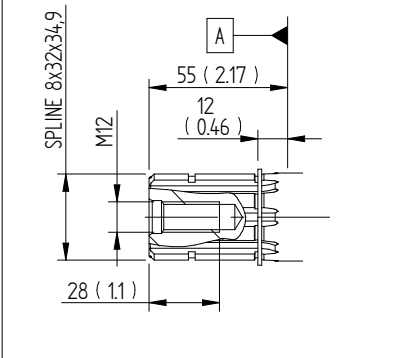

S0S Left rotation (L)

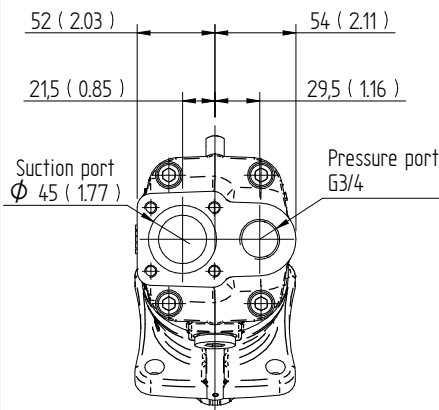

S0S Right rotation (R)

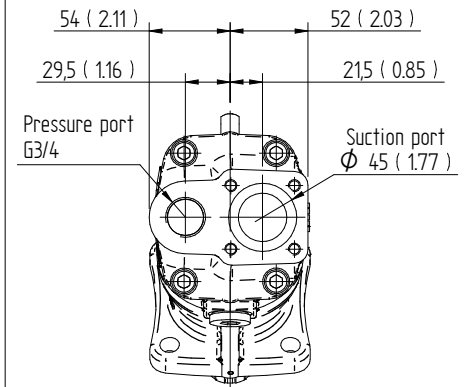

H35 DIN 5462 / ISO 14

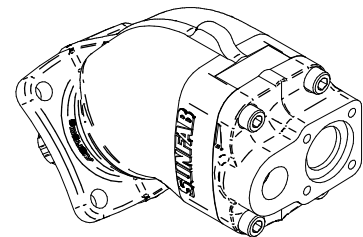
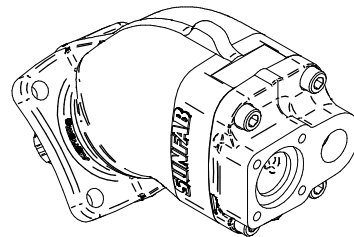
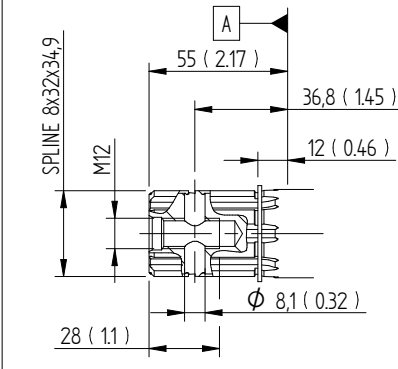

Dimensions SAP 040-064 DIN, SAPT 090 DIN

Millimeter (inch)

DL4 ISO 7653-D

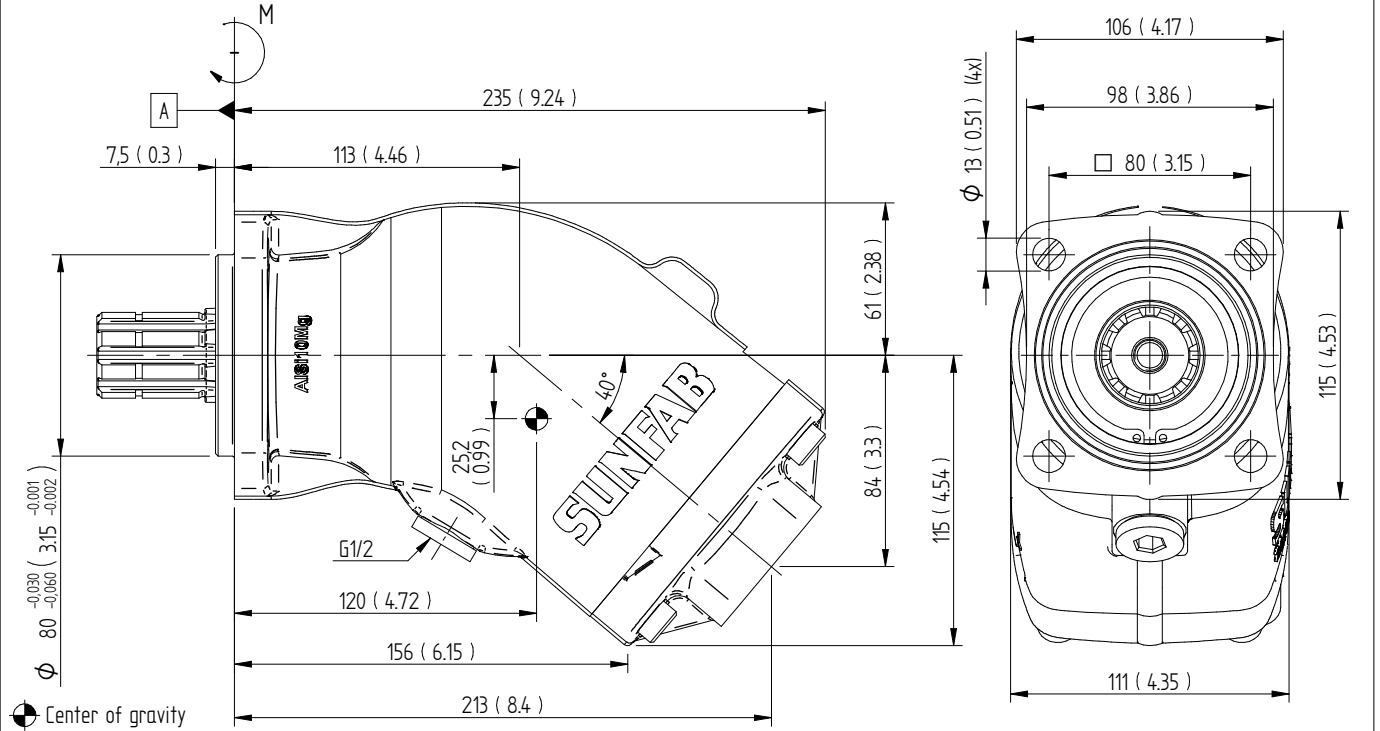

L35 DIN 5462 / ISO 14

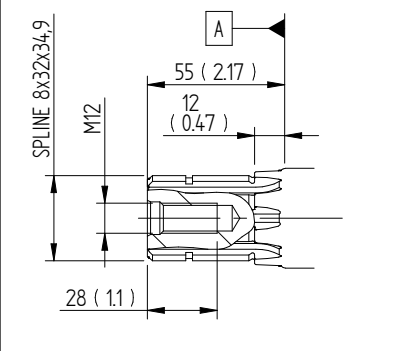

S0S Left rotation (L)

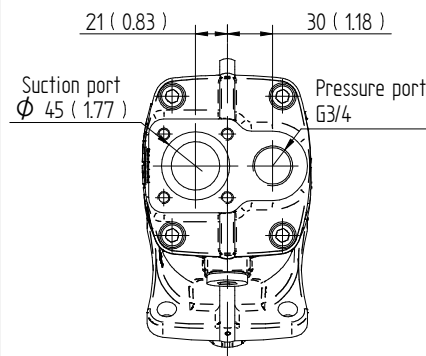

S0S Right rotation (R)

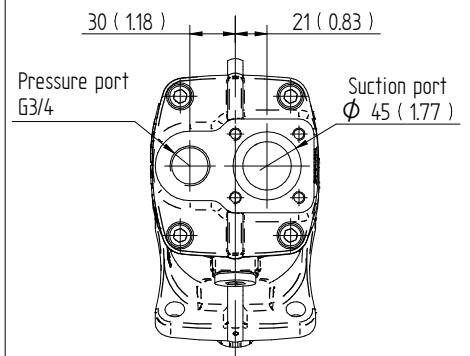

H35 DIN 5462 / ISO 14

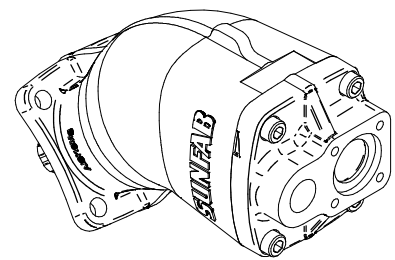
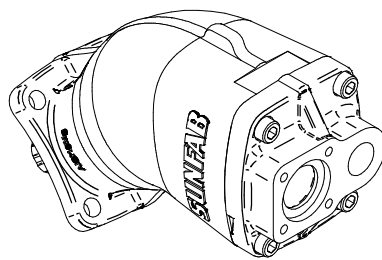
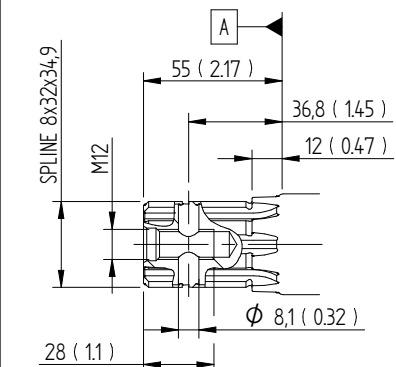

Dimensions SAP 084-108 DIN, SAPT 130 DIN

Millimeter (inch)

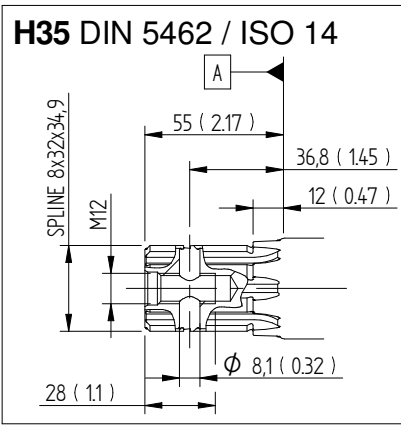
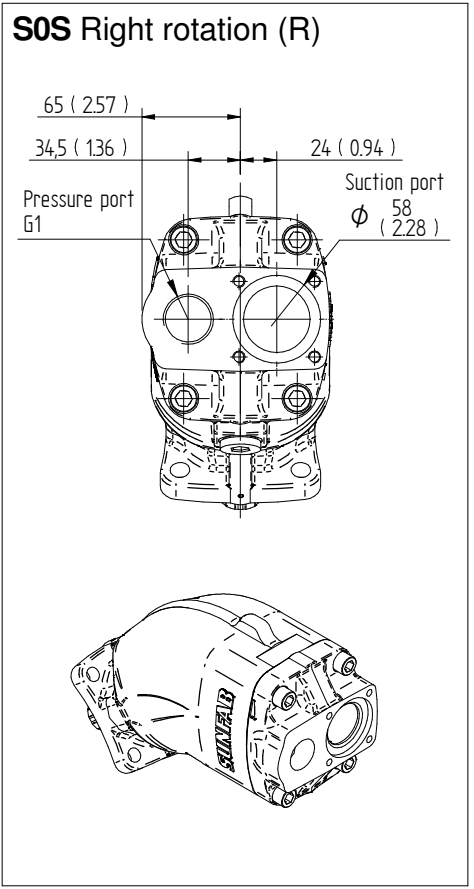
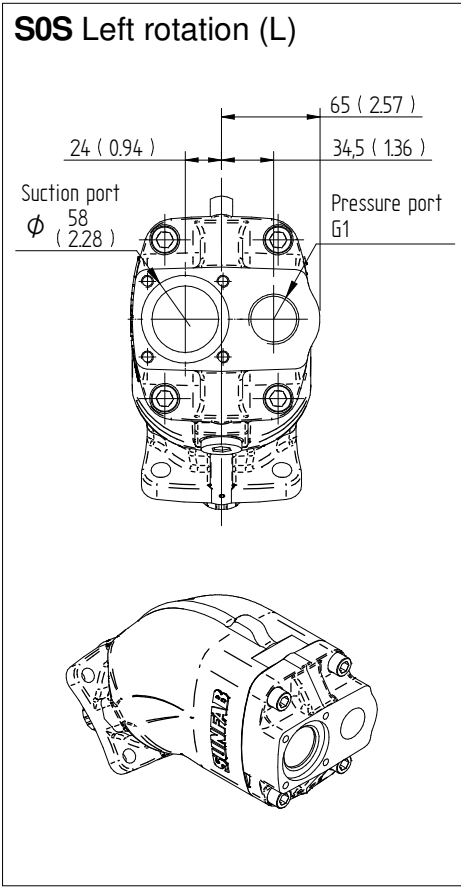
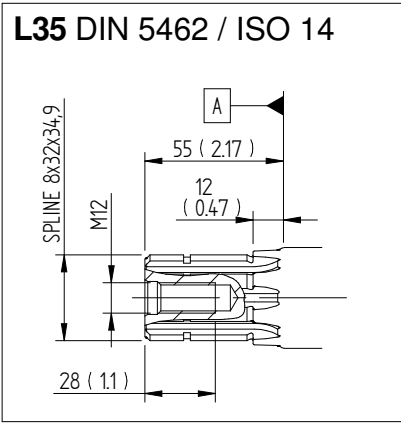
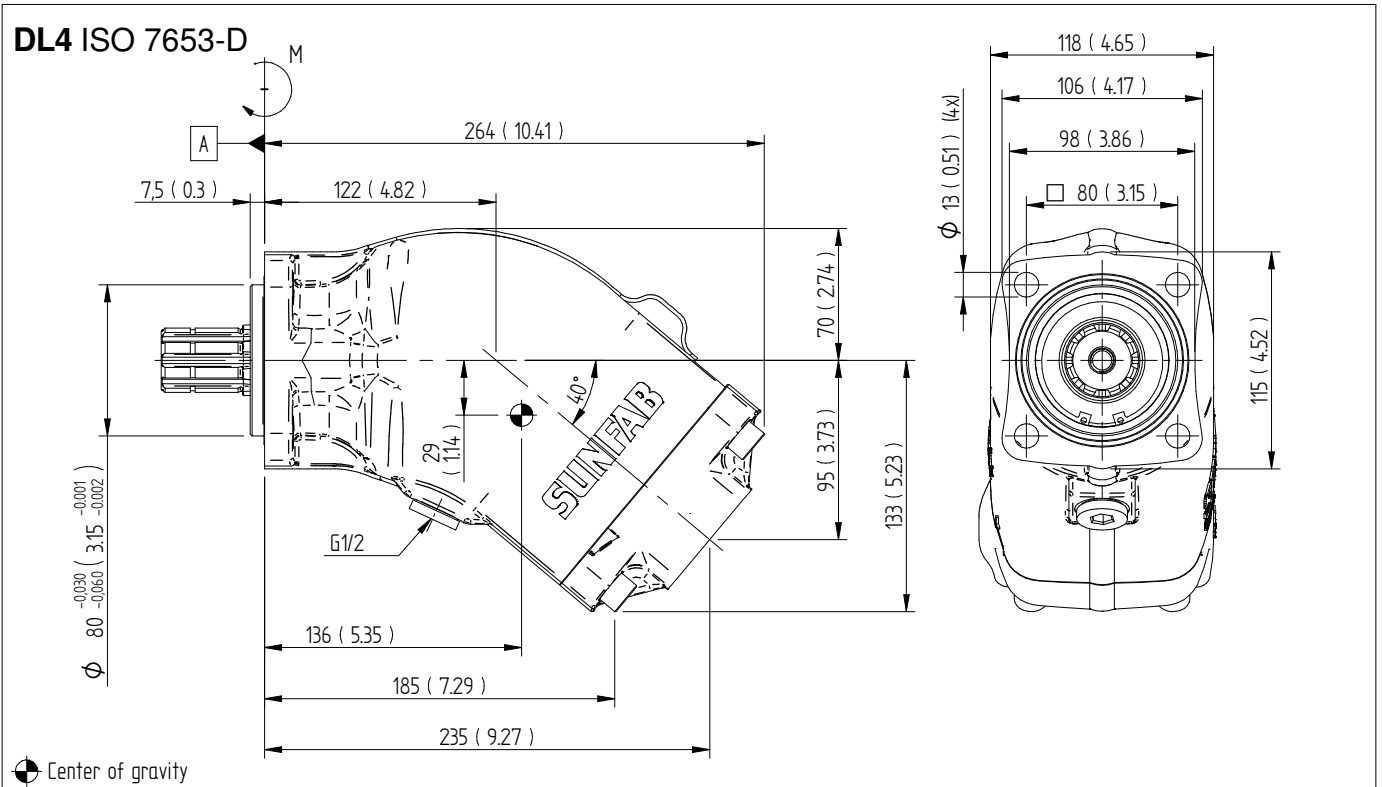



WARNING!

When the pump is running:

1. Do not touch the pressure hose
2. Watch out for rotating parts
3. The pump and hoses may be hot

Sunfab reserves the right to make changes in design and dimensions without notice. Printing and typesetting errors reserved.

© Copyright 2023 Sunfab Hydraulics AB. All Rights Reserved.